



PHOENIX

SPECIFICATIONS

VIVID SLIMLINE

SINK MIXER 220MM SQUARELINE

PRODUCT CODE: VS731 CHR
 FINISH: CHROME
 WELS: 4 STAR - 7.5 LT/MIN

INFORMATION:

TEMPERATURE RATING: MIN 1° - MAX 75°
 PRESSURE RATING: MIN 150 kPa - MAX 500 kPa



AVAILABLE IN:



CHROME MATTE BLACK

FOR MORE INFORMATION VISIT
www.phoenixtapware.com.au

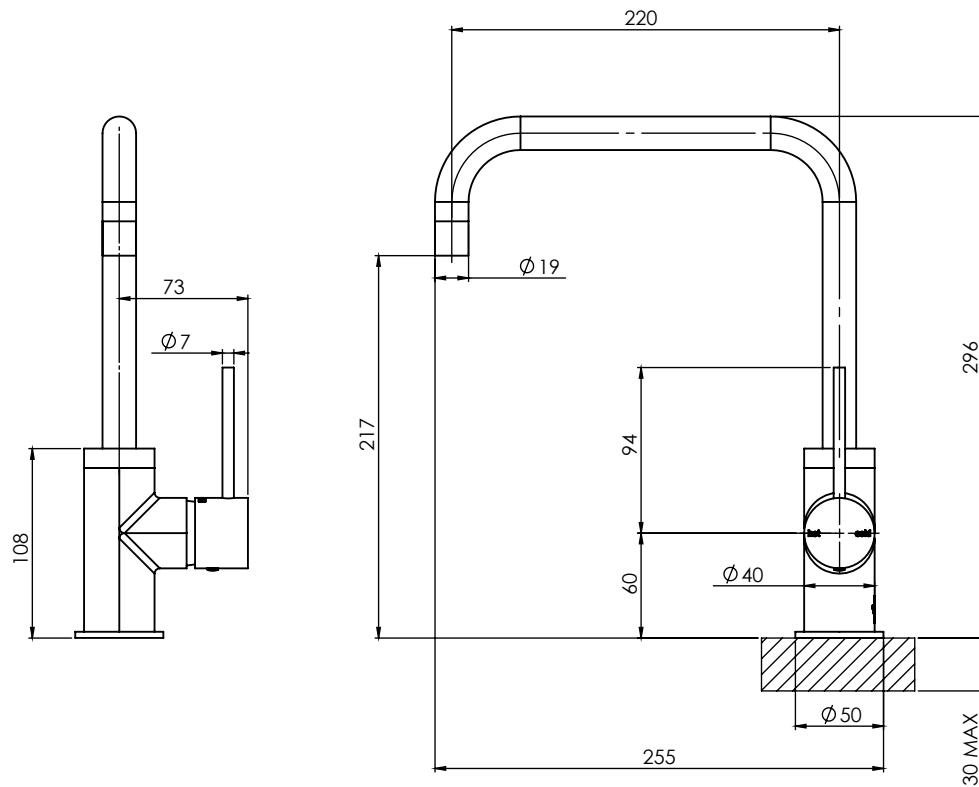

PLEASE [CLICK HERE TO VIEW FULL WARRANTY](#)

While we aim to ensure the specifications shown are correct at time of printing, Phoenix Tapware reserves the right to make modifications without prior notice. Always use the physical product measurements for mark-ups and roughing-in as the line drawing shown may differ from the actual product over time. All measurements are shown in millimetres.

www.phoenixtapware.com.au
03 9780 4200



PHOENIX

SPECIFICATIONS

VIVID SLIMLINE

SINK MIXER 220MM SQUARELINE

PRODUCT CODE:

VS731 CHR

FINISH:

CHROME

WELS:

4 STAR - 7.5 LT/MIN



PARTS LIST

1. MIXER BODY
2. SPOUT BOSS
3. MIXER BODY COVER
4. LOWER SPOUT DISC
5. UPPER SPOUT DISC
6. SQUARELINE SPOUT
7. O-RING 26X3.0MM
8. O-RING 7X2.5MM
9. 35MM CARTRIDGE
10. MIXER LOCKNUT
11. MIXER DOME
12. MIXER HANDLE
13. PIN LEVER
14. GRUB SCREW M5X6MM
15. AERATOR
16. AERATOR GASKET
17. AERATOR RETAINER
18. M8 THREADED ROD
19. RUBBER GASKET
20. M8 NUT
21. FLEXIBLE HOSE 450MM COLD
22. FLEXIBLE HOSE 450MM HOT
23. DRESS PLATE
24. GRUB SCREW CAP
25. O-RING 27X2.0MM
26. O-RING 39X3MM
27. FIXING PLATE

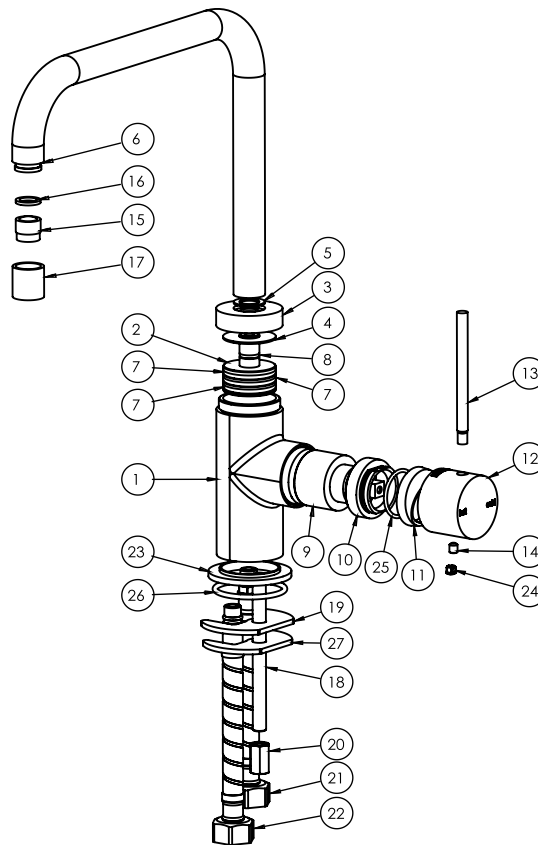

MAINTENANCE AND CARE:

- All surfaces should be cleaned with mild liquid detergent or soap and water.
- Do not use cream cleaners or citrus based cleaning products, as they are abrasive.
- Use of unsuitable cleaning agents may damage the surface. Any damage caused in this way will not be covered by warranty.

PACKAGING INCLUDES

- 1 x Sink mixer 220mm squareline
- 1 x Installation kit
- 1 x 450mm braided flexible cold hose
- 1 x 450mm braided flexible hot hose
- 1 x AF11 spanner
- 1 x Installation instructions
- 1 x Warranty card

PLEASE [CLICK HERE](#) TO VIEW FULL WARRANTY

While we aim to ensure the specifications shown are correct at time of printing, Phoenix Tapware reserves the right to make modifications without prior notice. Always use the physical product measurements for mark-ups and roughing-in as the line drawing shown may differ from the actual product over time. All measurements are shown in millimetres.

www.phoenixtapware.com.au
03 9780 4200